

SCHEMI DI RIPRISTINO PAVIMENTAZIONI

MARCIAPIEDE CON PAVIMENTAZIONE IN CONGLOMERATO BITUMINOSO

SCAVI LONGITUDINALI

MARCIAPIEDE IN CONGLOMERATO BITUMINOSO

SCHEMA RIPRISTINO PROVVISORIO

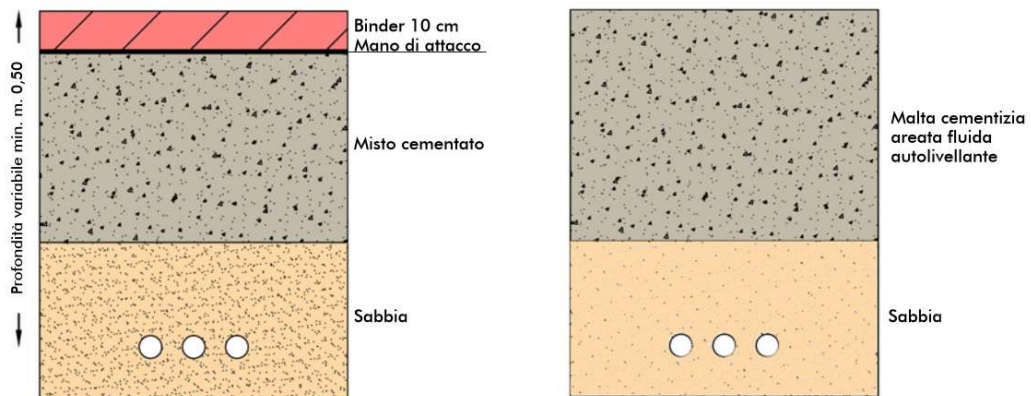

SCHEMA RIPRISTINO DEFINITIVO

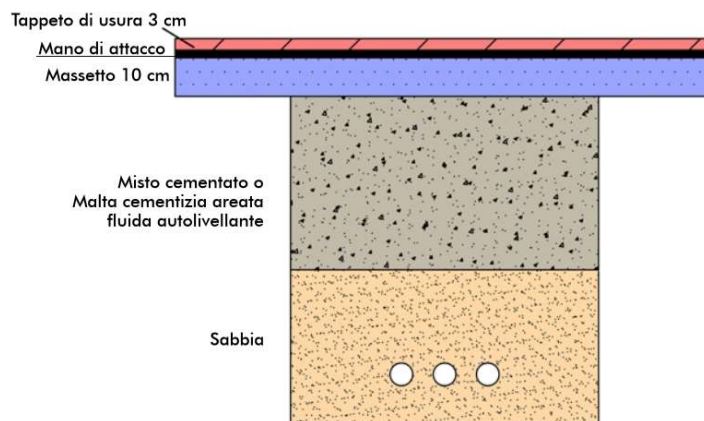

SCAVI SU MARCIAPIEDE

Scavo parallelo all'asse del marciapiede

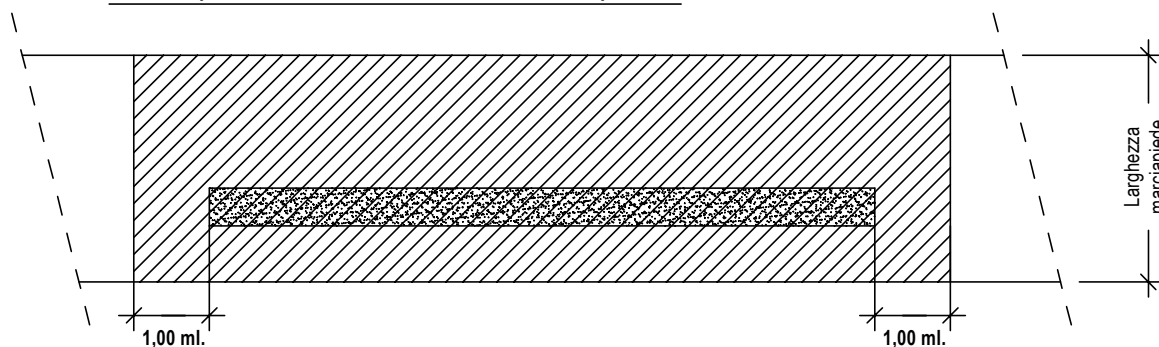

Scavo trasversale all'asse del marciapiede

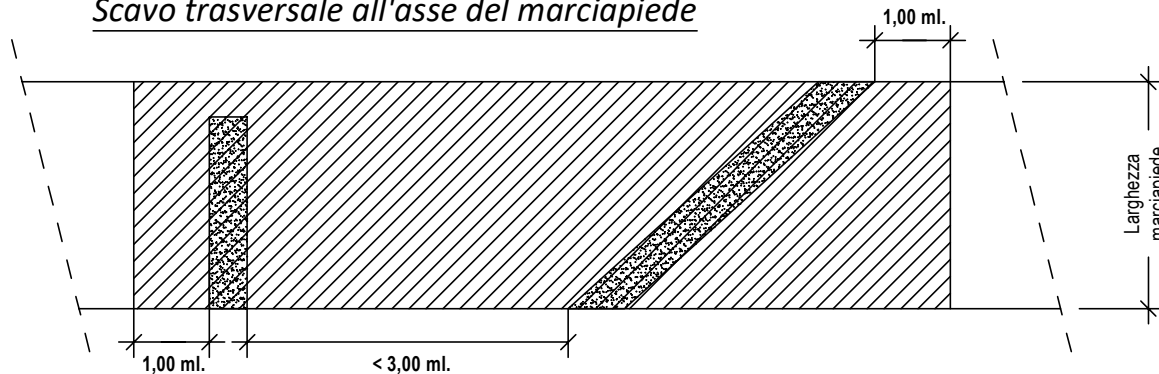

Scavo trasversale all'asse del marciapiede

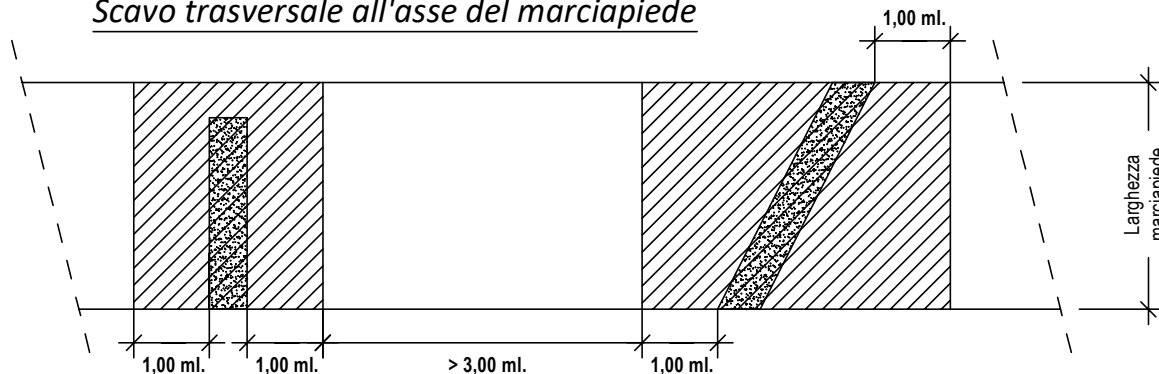

Area di scavo



Area di ripristino definitivo

STRADE CON PAVIMENTAZIONE IN CONGLOMERATO BITUMINOSO

SCAVI LONGITUDINALI

SCHEMA RIPRISTINO PROVVISORIO

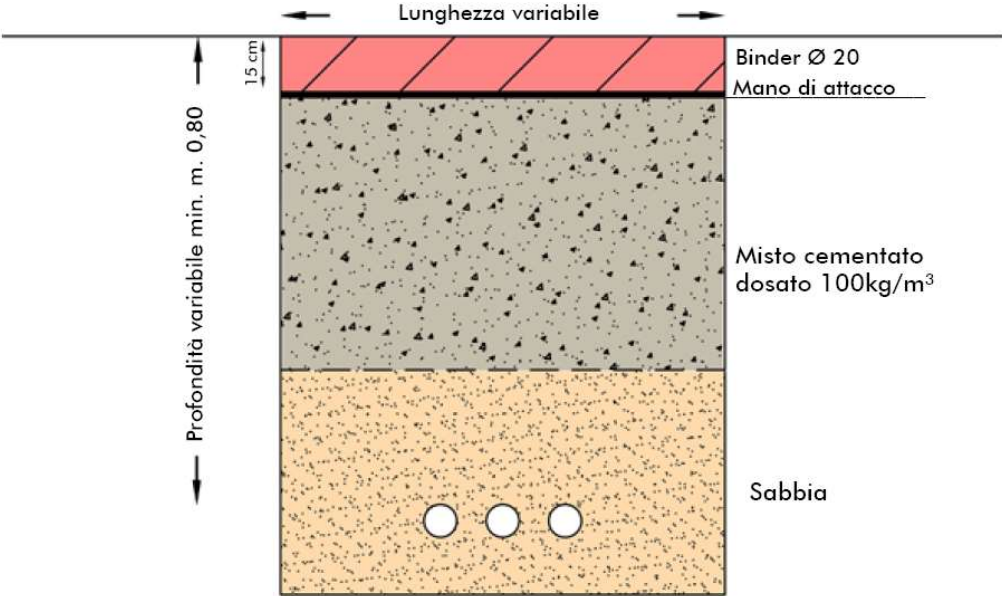

SCHEMA RIPRISTINO DEFINITIVO

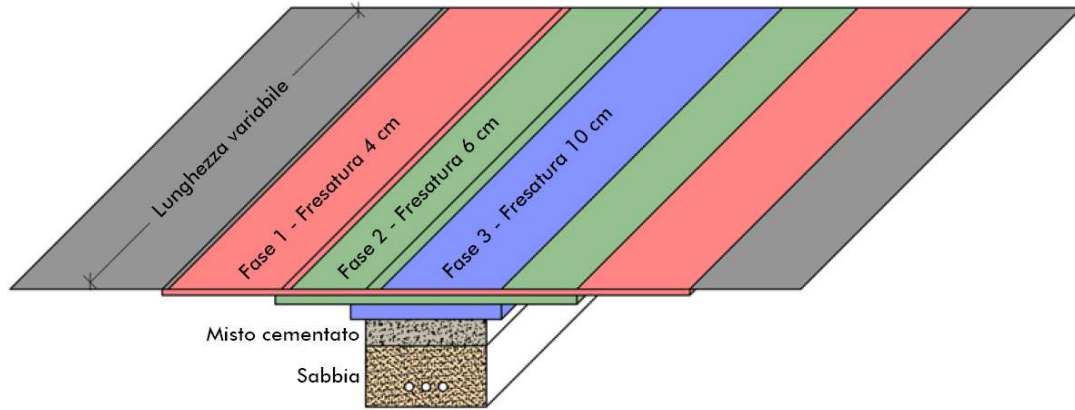

Carreggiata/Corsia stradale

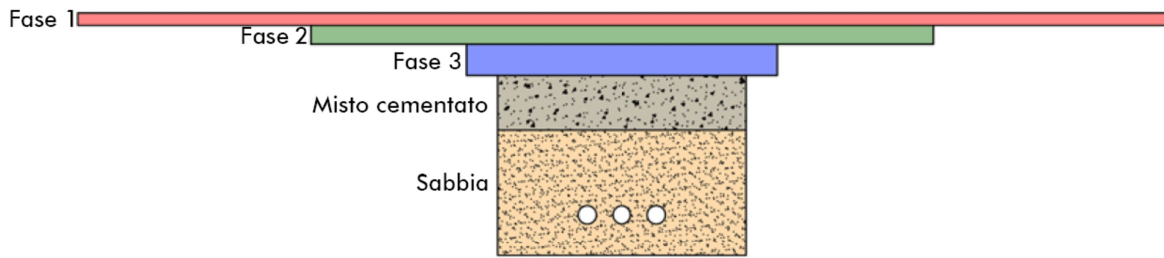

Carreggiata/Corsia stradale

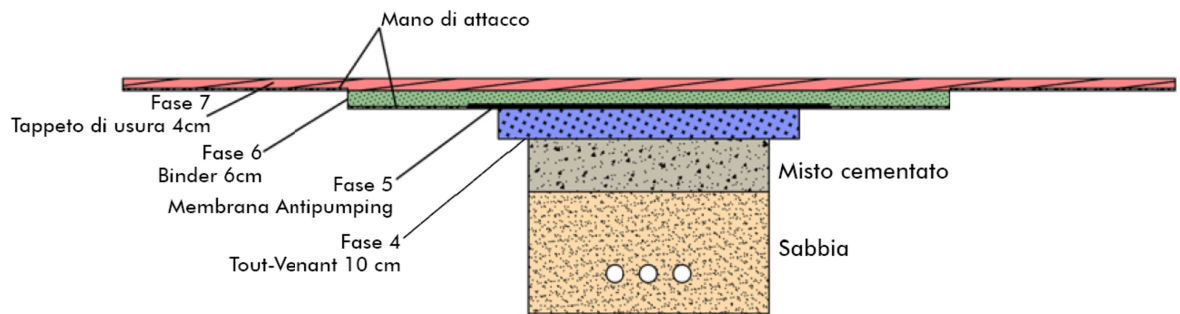

Carreggiata/Corsia stradale

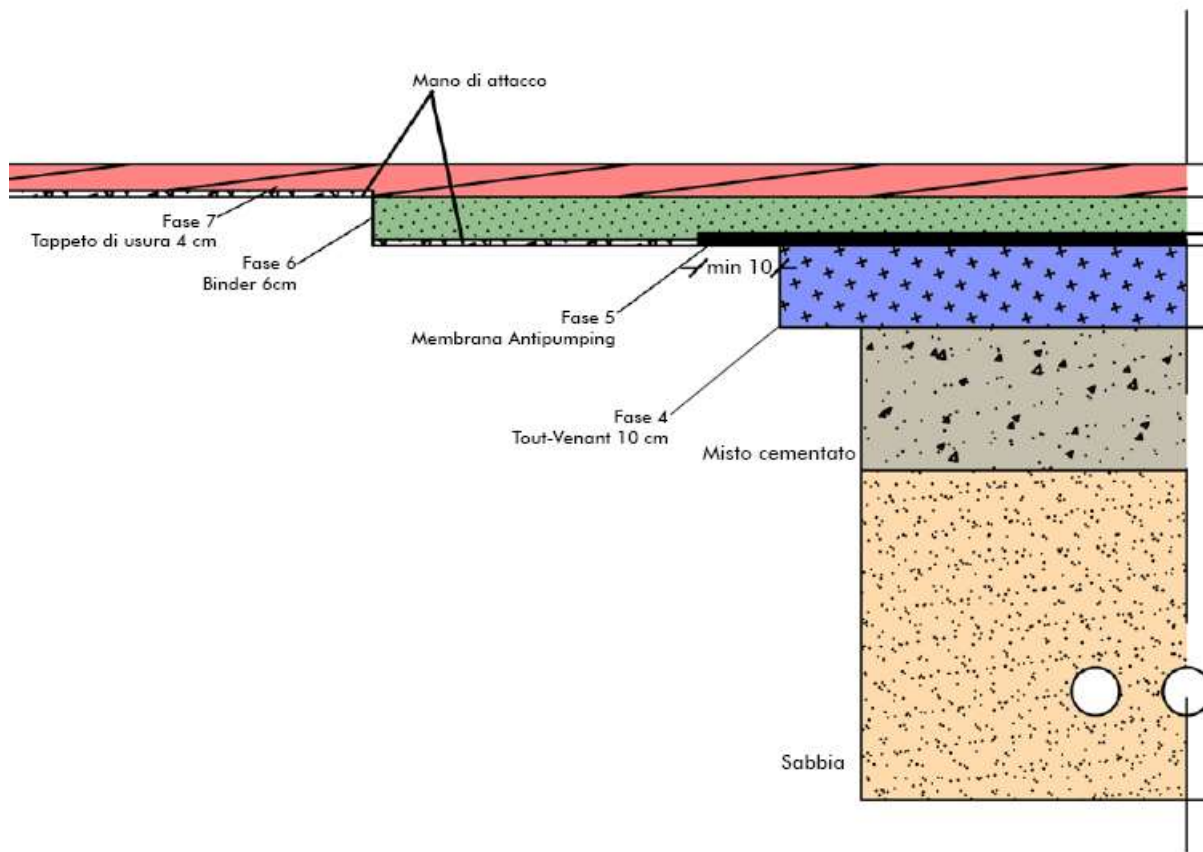

SCAVI SU STRADE CON CARREGGIATA MINORE DI ML. 7,00

Scavo parallelo all'asse della strada

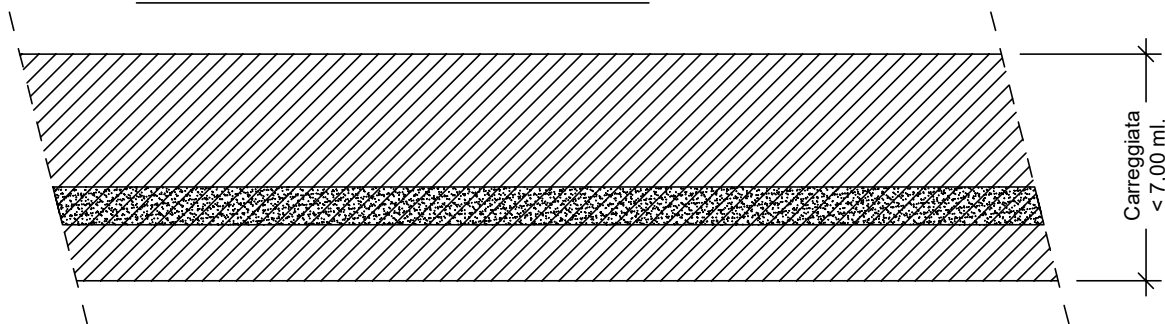

Scavo trasversale all'asse della strada

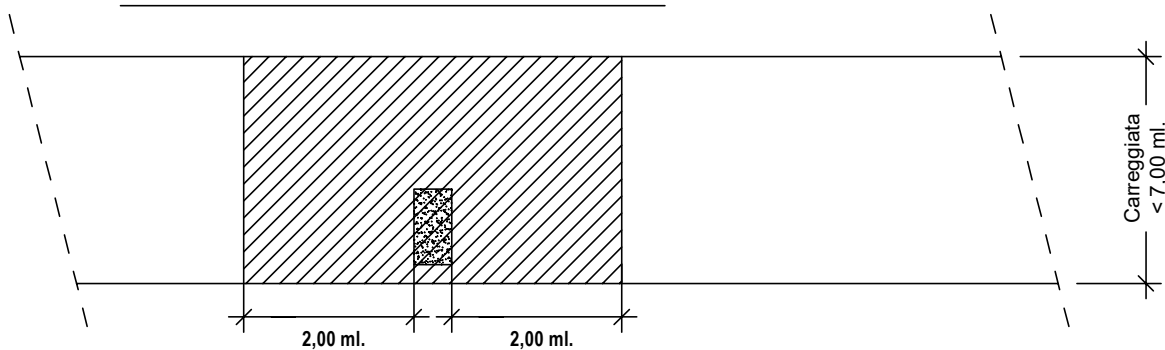

Scavo trasversale all'asse della strada

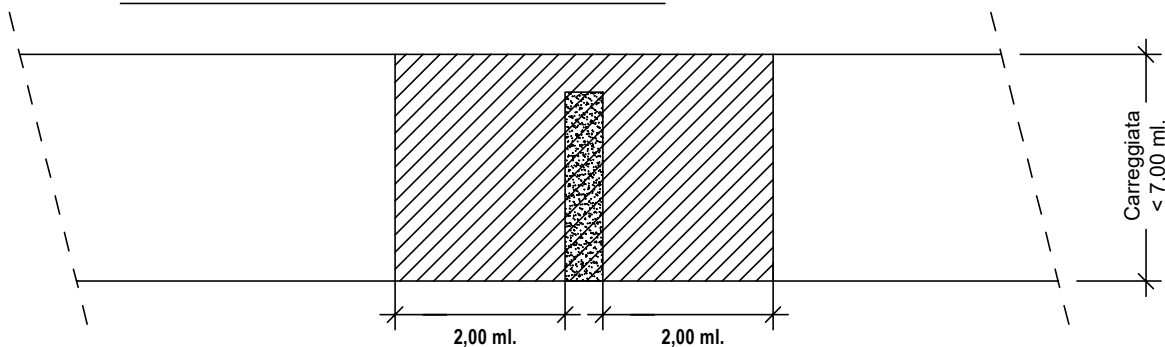

Area di scavo



Area di ripristino definitivo

SCAVI SU STRADE CON CARREGGIATA MINORE DI ML. 7,00

Scavi multipli trasversali all'asse della strada

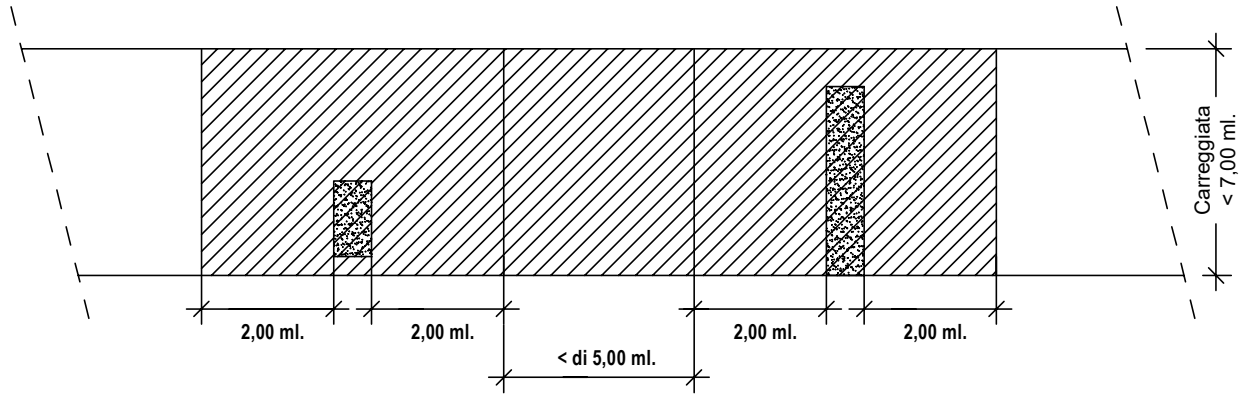

Scavi multipli trasversali all'asse della strada

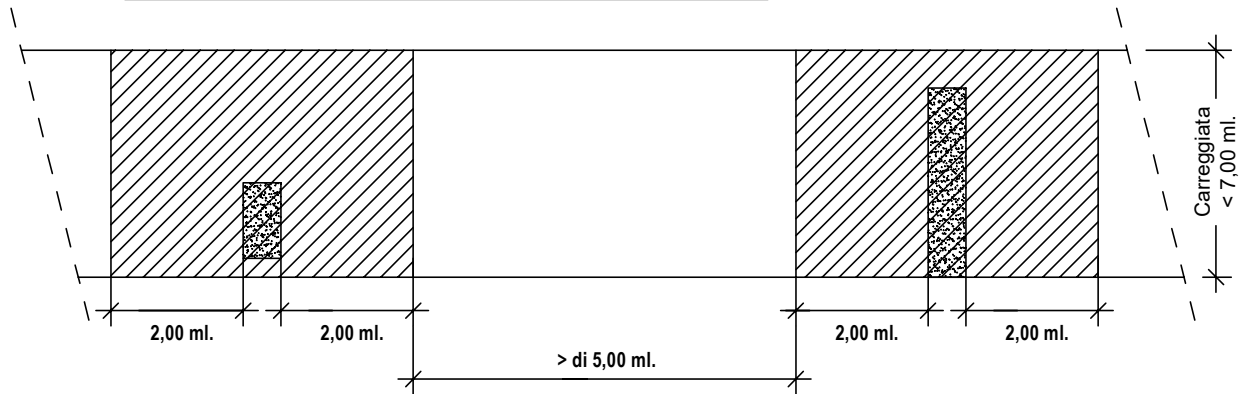

 Area di scavo

 Area di ripristino definitivo

SCAVI SU STRADE CON CARREGGIATA MAGGIORE DI ML. 7,00

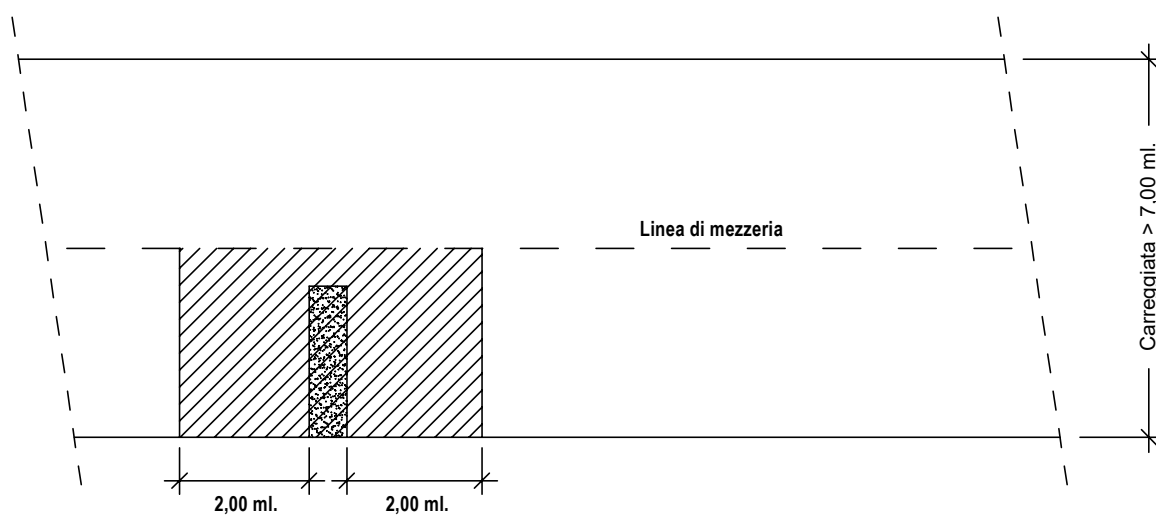
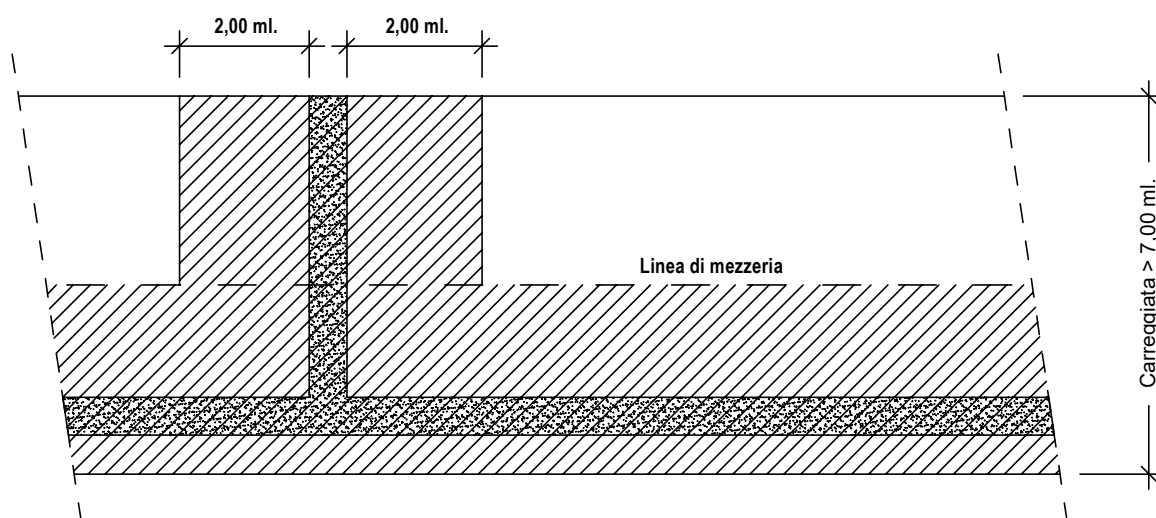

 *Area di scavo*

 *Area di ripristino definitivo*

SCAVI SU STRADE CON CARREGGIATA MAGGIORE DI ML. 7,00

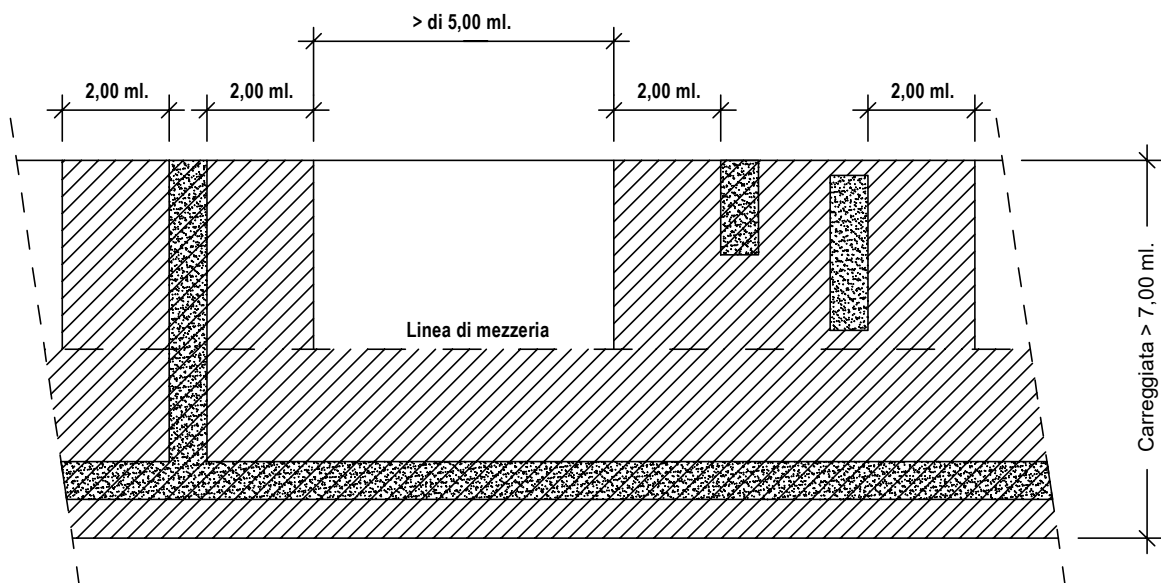
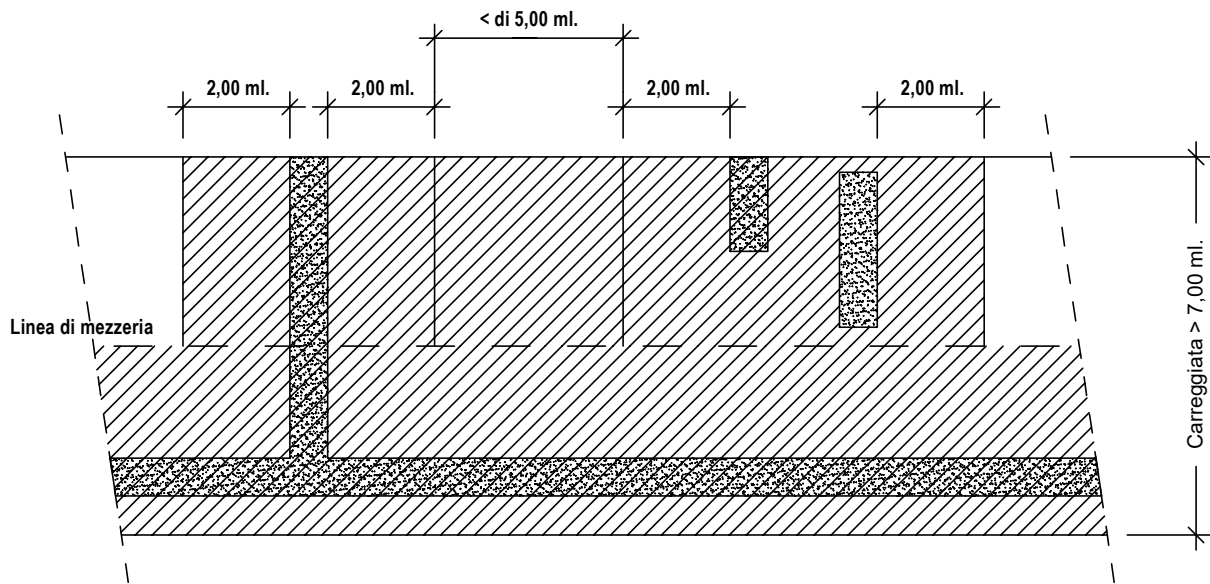

 Area di scavo

 Area di ripristino definitivo

SCAVI SU STRADE CON CARREGGIATA MAGGIORE DI ML. 7,00

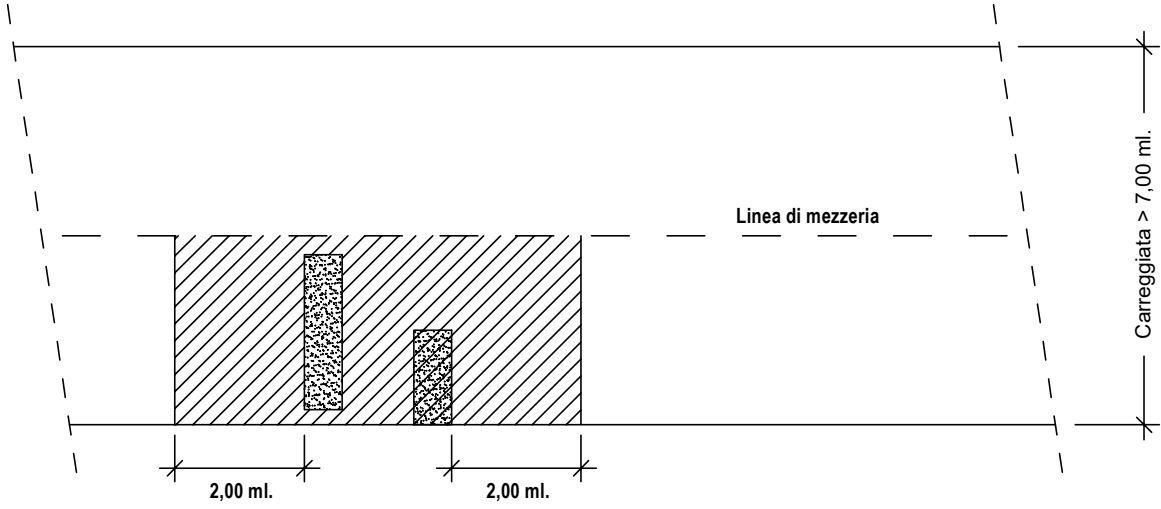
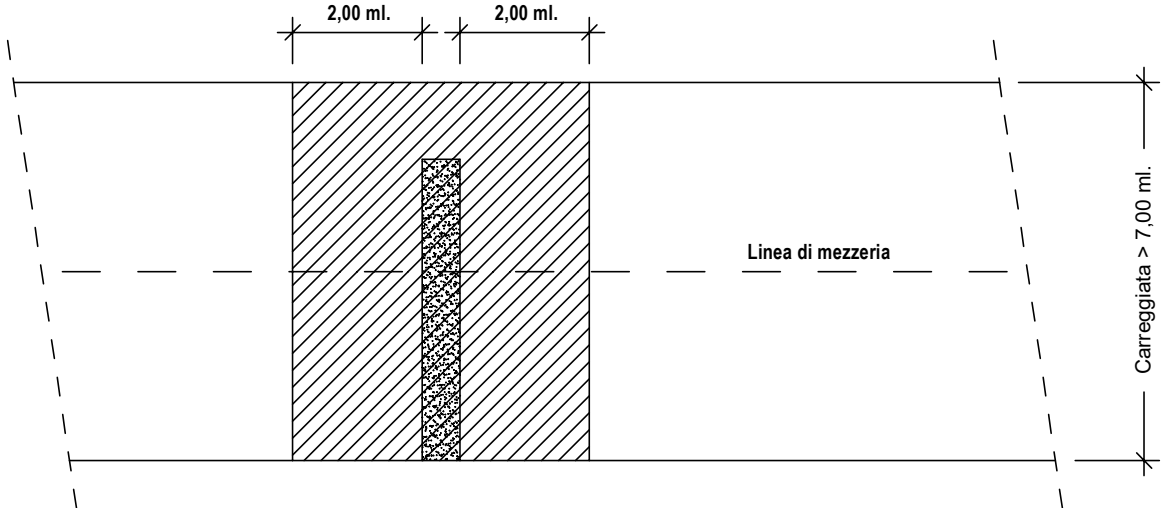

 *Area di scavo*

 *Area di ripristino definitivo*

MARCIAPIEDI CON PAVIMENTAZIONE IN MATERIALI LAPIDEI

SCHEMA RIPRISTINO

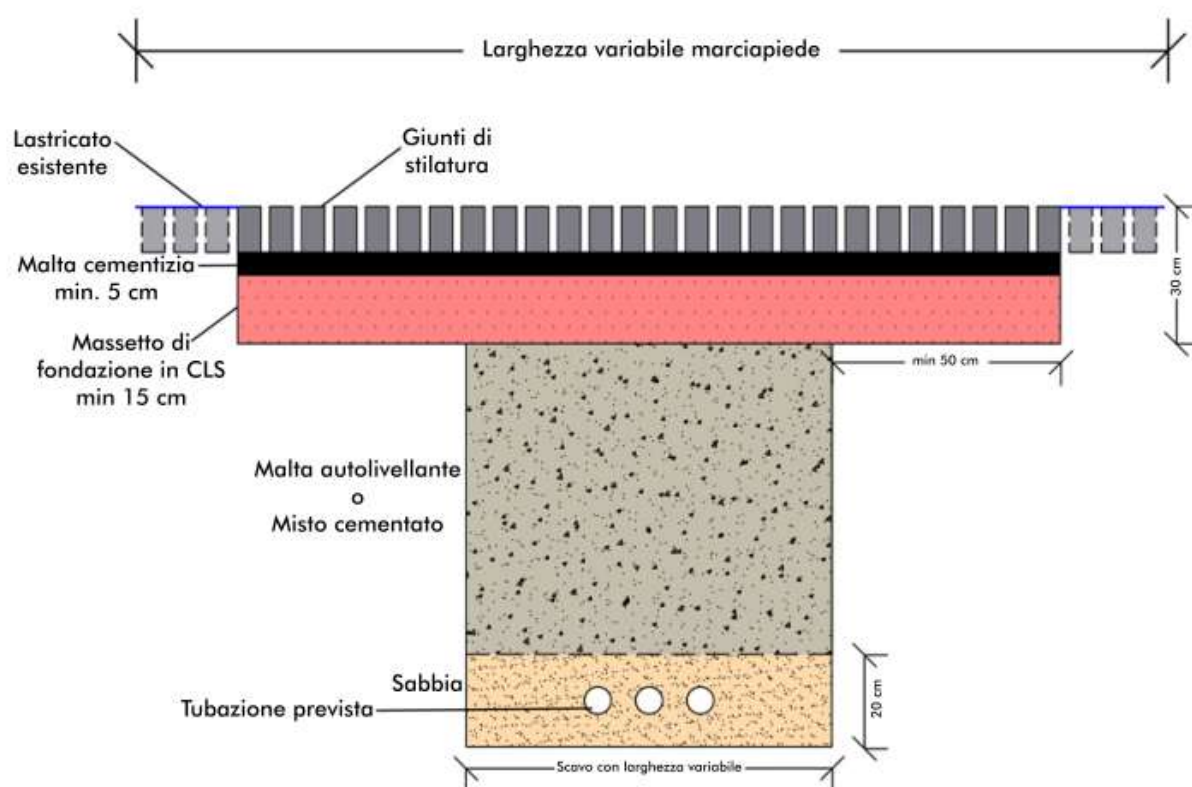

*Le misure indicate potranno essere variate a seguito di particolari esigenze legate alla tipologia, spessore e dimensioni degli elementi lapidei costituenti il lastricato da ripristinare

SCAVI SU MARCIAPIEDE CON PAVIMENTAZIONE IN MATERIALE LAPIDEO

Scavo parallelo all'asse del marciapiede

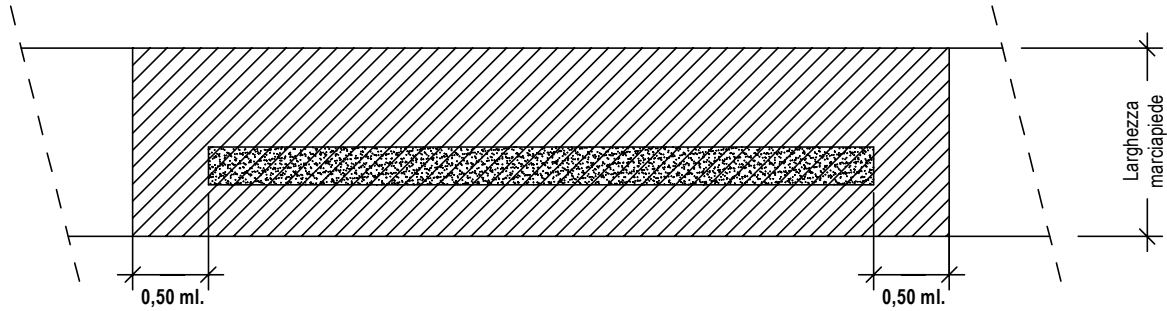

Scavo trasversale all'asse del marciapiede

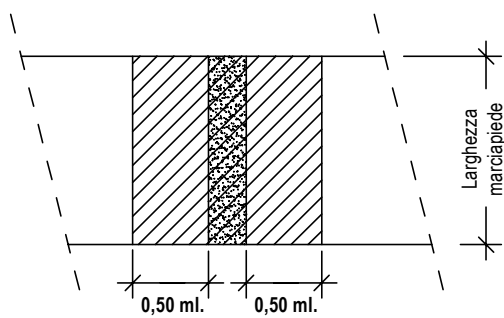

Scavo obliquo all'asse del marciapiede

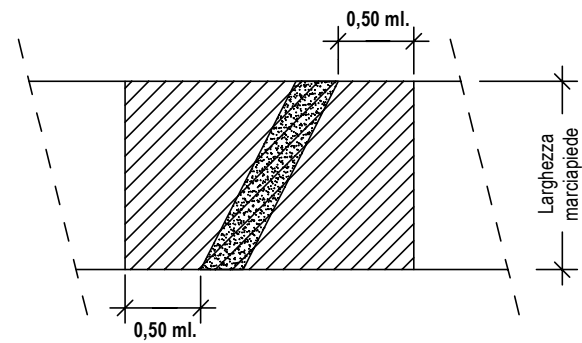

Scavo obliquo e/o trasversale all'asse del marciapiede

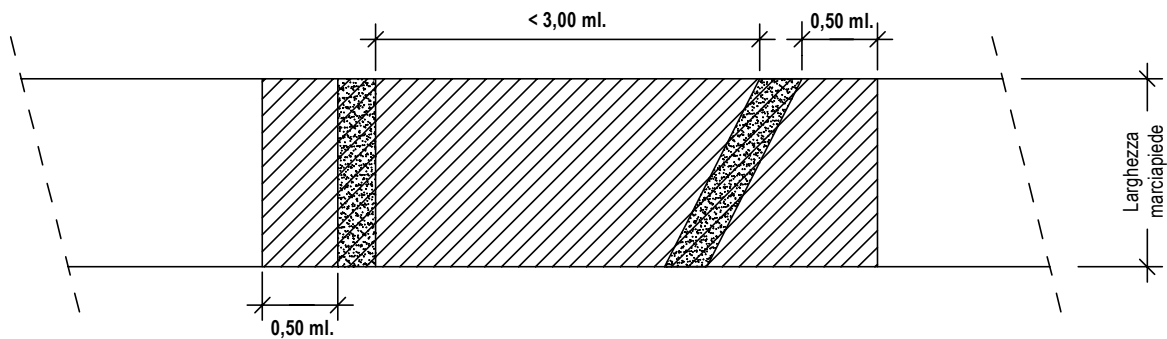

 Area di scavo

 Area di ripristino definitivo

INTERVENTI SU OPERE DI RECENTE REALIZZAZIONE

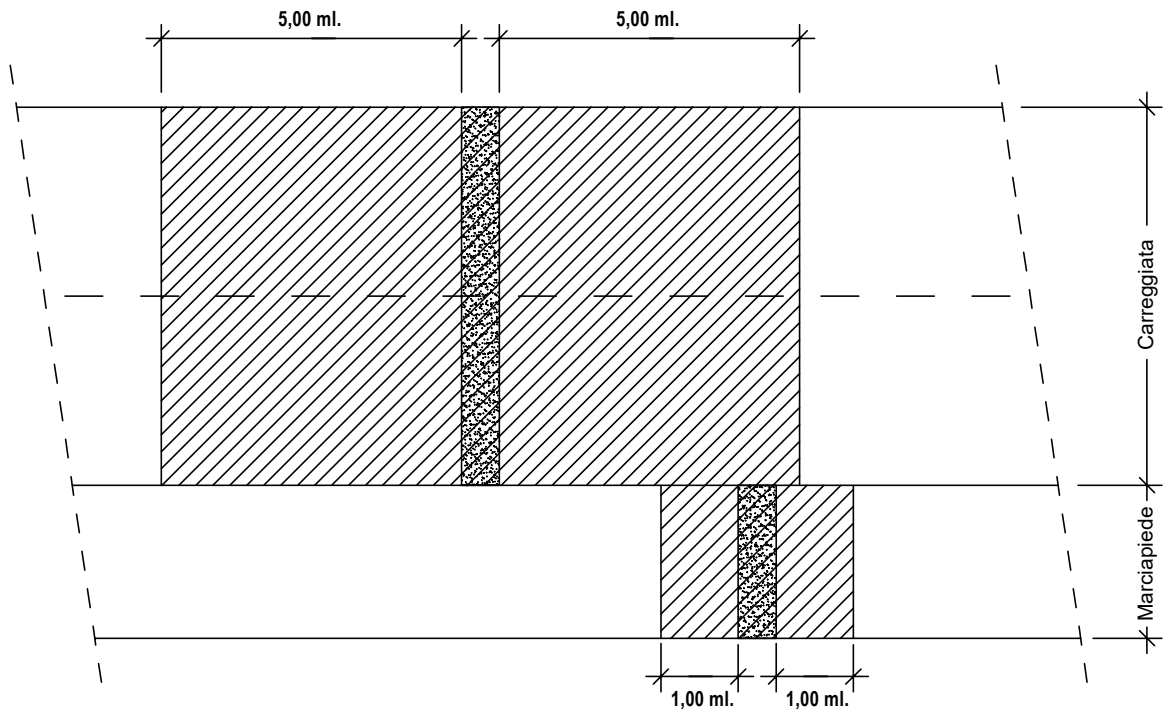
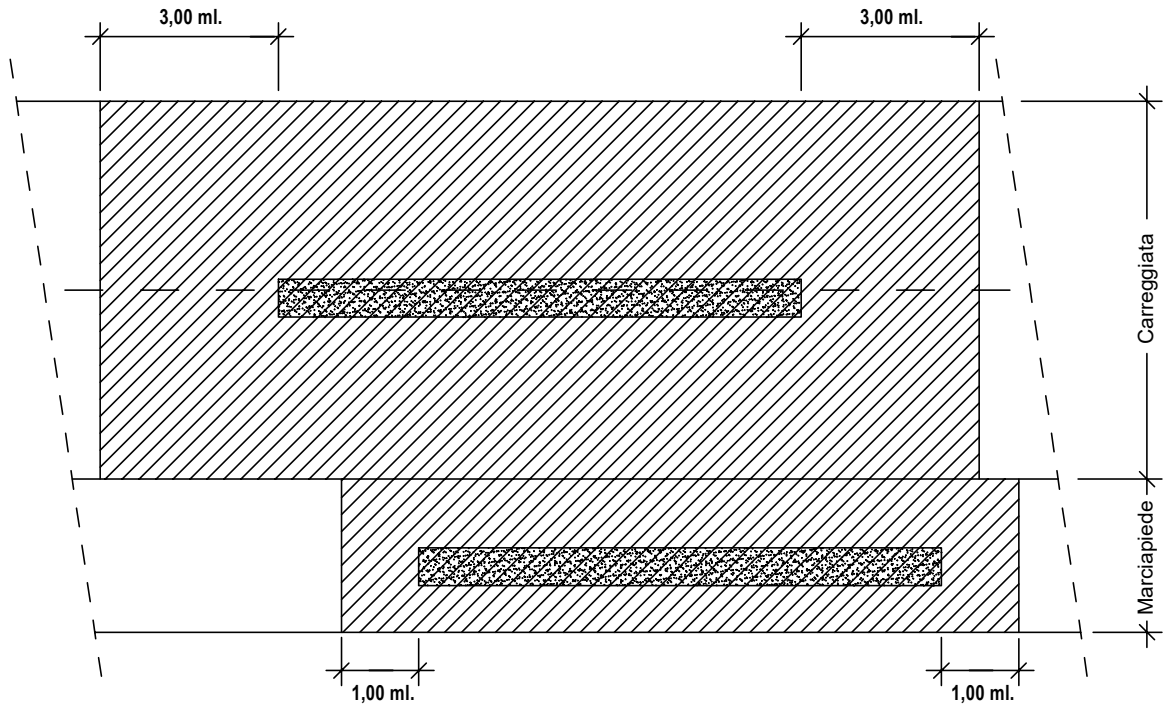

 *Area di scavo*

 *Area di ripristino definitivo*

INTERVENTI SU OPERE DI RECENTE REALIZZAZIONE

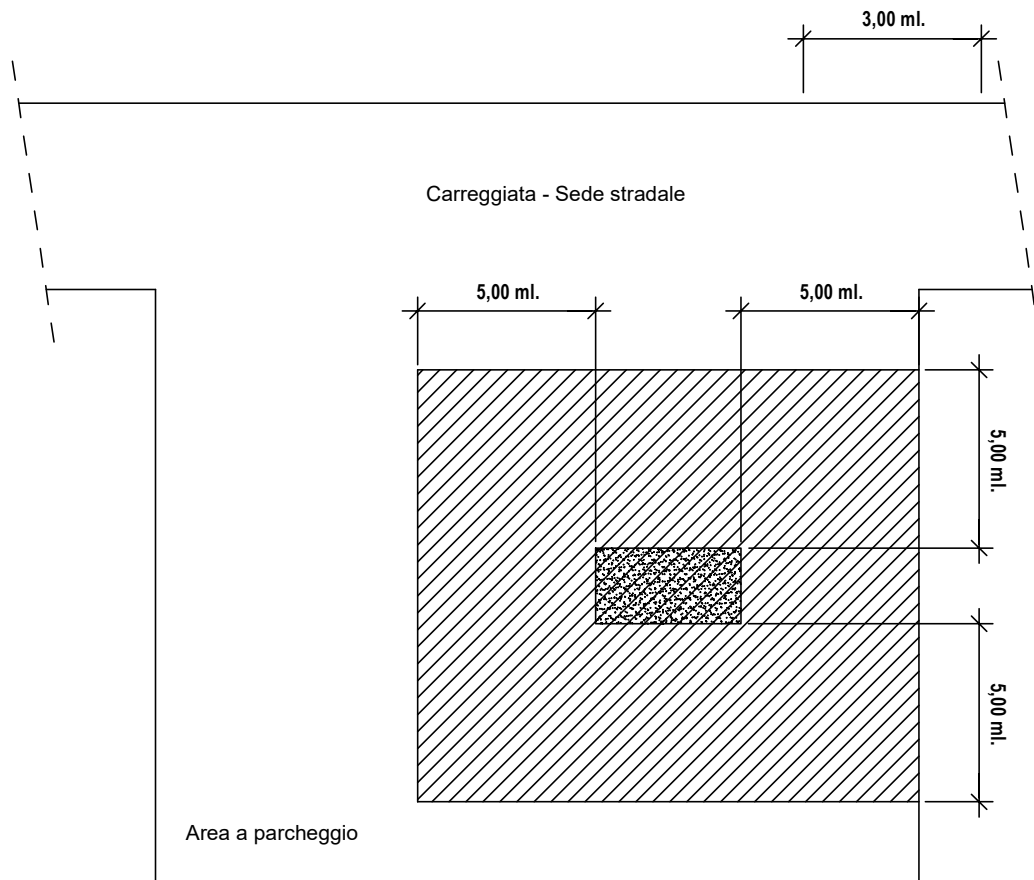

Area di scavo



Area di ripristino definitivo

SCAVO IN MINITRINCEA

Modalità di ripristino di pavimentazione in conglomerato bituminoso

FASE 1
Scavo in minitrincea
e posa cavidotto

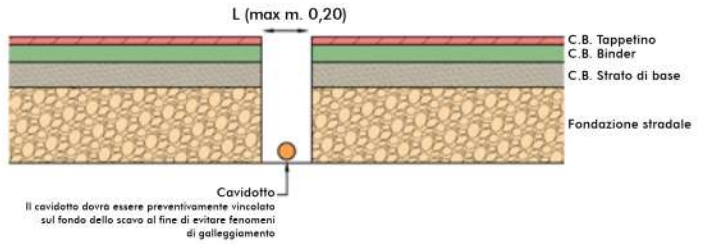

RIPRISTINO PROVVISORIO

TEMPISTICA: ENTRO 48 ORE DALLA MANOMISSIONE DEL SUOLO

FASE 2
Riempimento dello scavo con
malta cementizia areata fluida
autolivellante a presa rapida

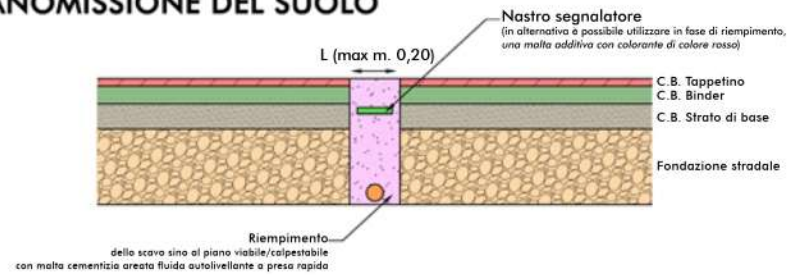

RIPRISTINO DEFINITIVO

TEMPISTICA: ENTRO 30 GIORNI DAL RIEMPIMENTO DELLO SCAVO

FASE 3
Fresatura pavimentazione
stradale e posa membrana
impermeabilizzante

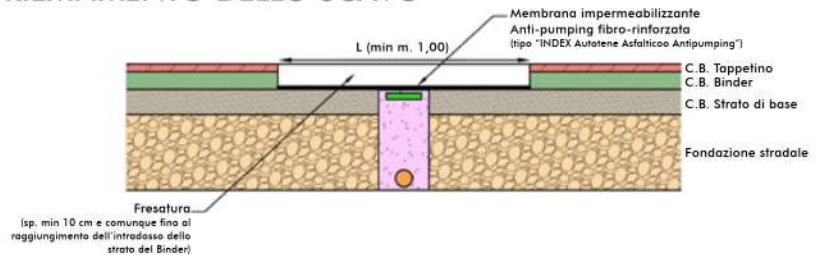

FASE 4
Stesa strato conglomerato
bituminoso Binder

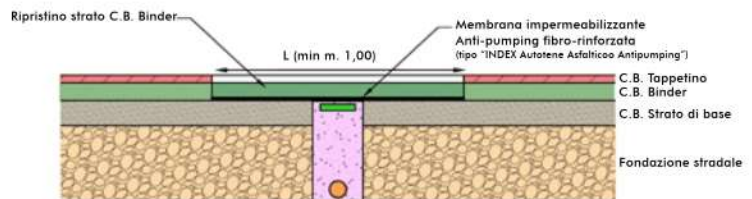

FASE 5
Stesa del tappetino in
conglomerato bituminoso

